

AirBus-AE525 Wingbox contest (Fall 2021)

- Design and Build the **lightest semi-monocoque wingbox** to withstand the bending and twisting loads. The cantilevered wingbox weighing **no more than 0.7 lbs** must carry a dead load 'Q' of 5 lbs and minimum end load 'P' of **15 lbf** to qualify. The wingbox will be tested to failure and the team achieving the highest score based on a weighted rubric will be the winner. The score will be based on the wing design documentation, construction quality, and performance.

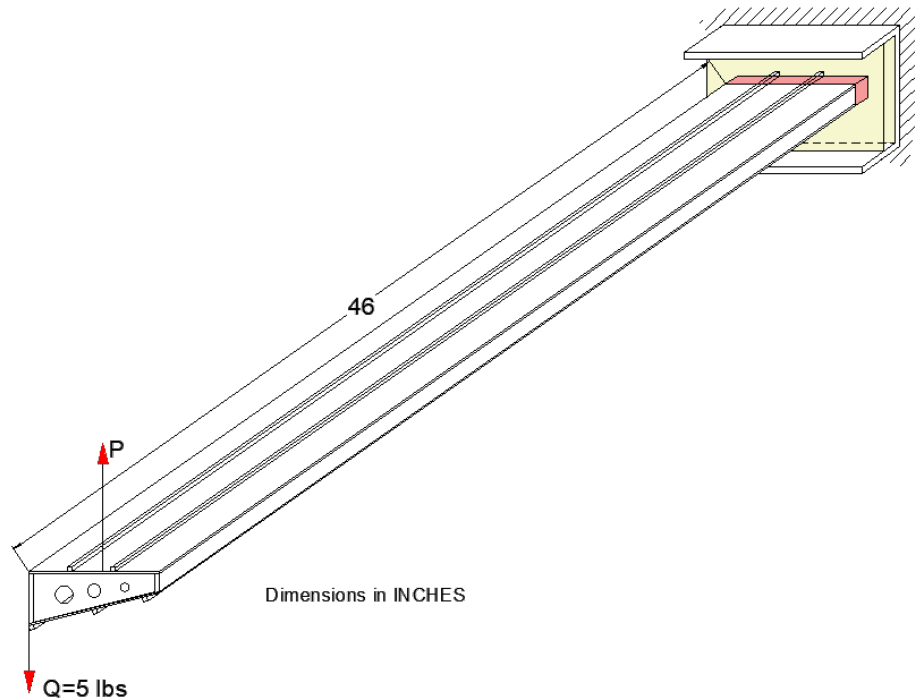

Eligibility:

Open to student groups (≤ 4) enrolled in the Fall 2021 AE 525 course

Deadlines:

Entry : Enrolled in AE 525

Submission : **5PM (CDT), December 3rd 2021**

Awards:

1st Place : \$1000

2nd Place : \$500

3rd Place : \$250

Geometry

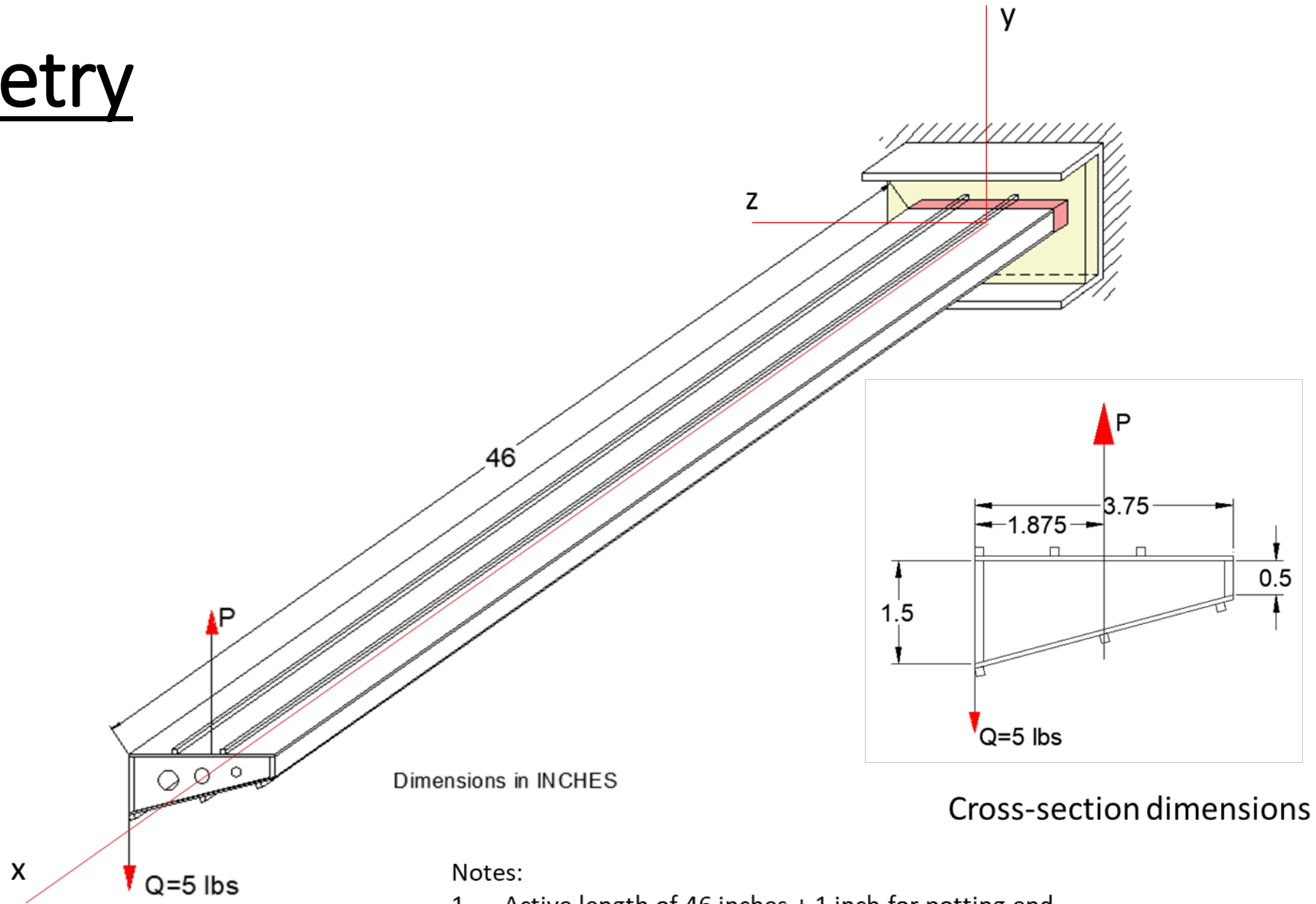

Notes:

1. Active length of 46 inches + 1 inch for potting end
2. The stringers must be placed on the outside.
3. End will be potted by Flight Structures Lab

Loading

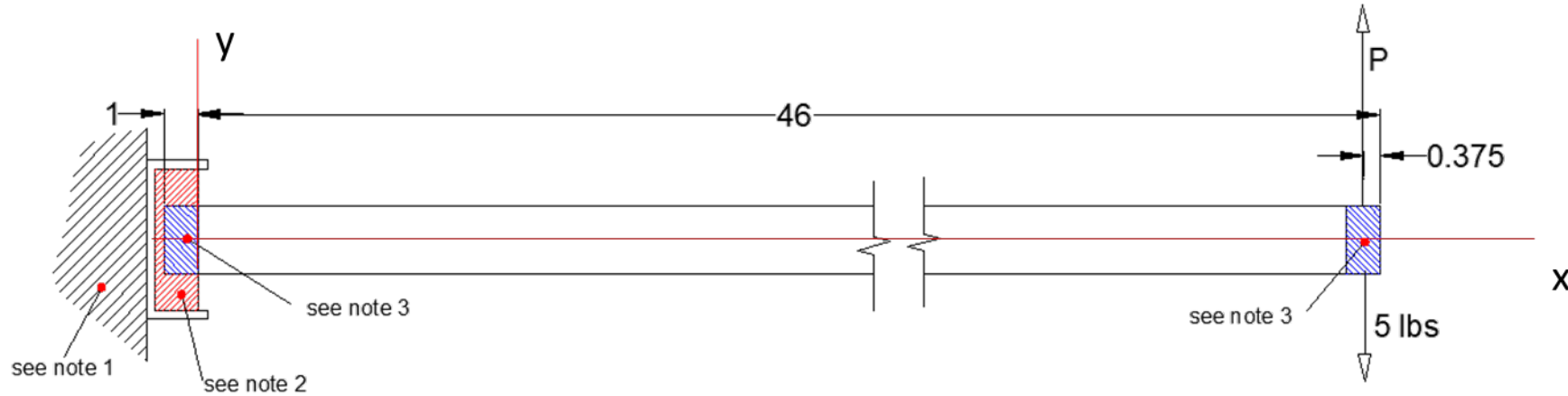

Dimensions in INCHES

NOTES

1. Rigid support
2. End potted in epoxy resin
3. Ends to be reinforced with 1.00 in thick balsa rib

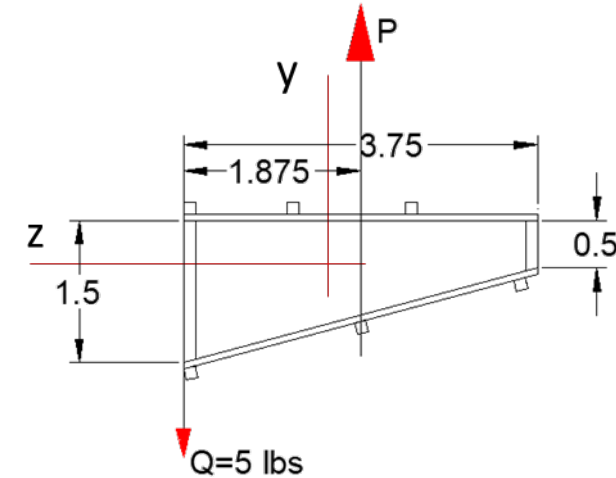

NOTE: The teams will be provided with Balsa ribs (1.00in thick) to be inserted at the free and fixed ends. The stringers, spars and skin must extend the entire length (47 inches)

Scoring rubric

The designs will be scored based on the following formula

$$Score = S_{performance} + S_{analysis} + S_{report}$$

$$S_{performance} = 0.5 \frac{P_{max}}{W_{Wing}} + 0.1 \frac{Q}{\delta_Q} + 0.05 \left[\frac{P_{max}}{\delta_{max}} + \frac{P_{max}}{\theta_{max}} \right] - 10 \frac{W_{Wing}}{0.7}$$

$$S_{analysis} = 10 \left(1 - f \left(P_{max}, P_{pred}, 0.1 \right) \right) + 10 \left(1 - f \left(\delta_Q, \delta_{Q_pred}, 0.1 \right) \right) + 10 \left(1 - f \left(\delta_{15}, \delta_{15_pred}, 0.1 \right) \right)$$

$$f(A, A_{pred}, \beta) = \begin{cases} 0 & \frac{|A - A_{pred}|}{A_{pred}} \leq \beta \\ \frac{|A - A_{pred}|}{A_{pred}} - \beta & otherwise \end{cases}$$

Note : The tolerances for strength and stiffness are based on variability in material properties.

W_{TOTAL} ~ Total weight (wing box + end block)

$W_{SUPPORT}$ ~ Weight of end block

W_{WING} ~ weight of wingbox (lbs)
(should not exceed 0.7 lbs)

P_{max} ~ Measured failure load

P_{pred} ~ predicted failure load (lbs)

δ_{15} ~ Measured end deflection (along load) at P=15 lbs (+Q=5lbs)

δ_{15_pred} ~ Predicted end deflection (along load) at P=15 lbs (+Q=5lbs)

δ_Q ~ Measured end deflection (along load) at Q=5 lbs

δ_{Q_pred} ~ Predicted end deflection (along load) at Q=5 lbs

δ_{max} ~ Measured end deflection at failure

θ_{max} ~ Measured end twist at failure (degrees)

AIRBUS



AirBus-AE525 Wingbox contest (2021 Fall) :Winners

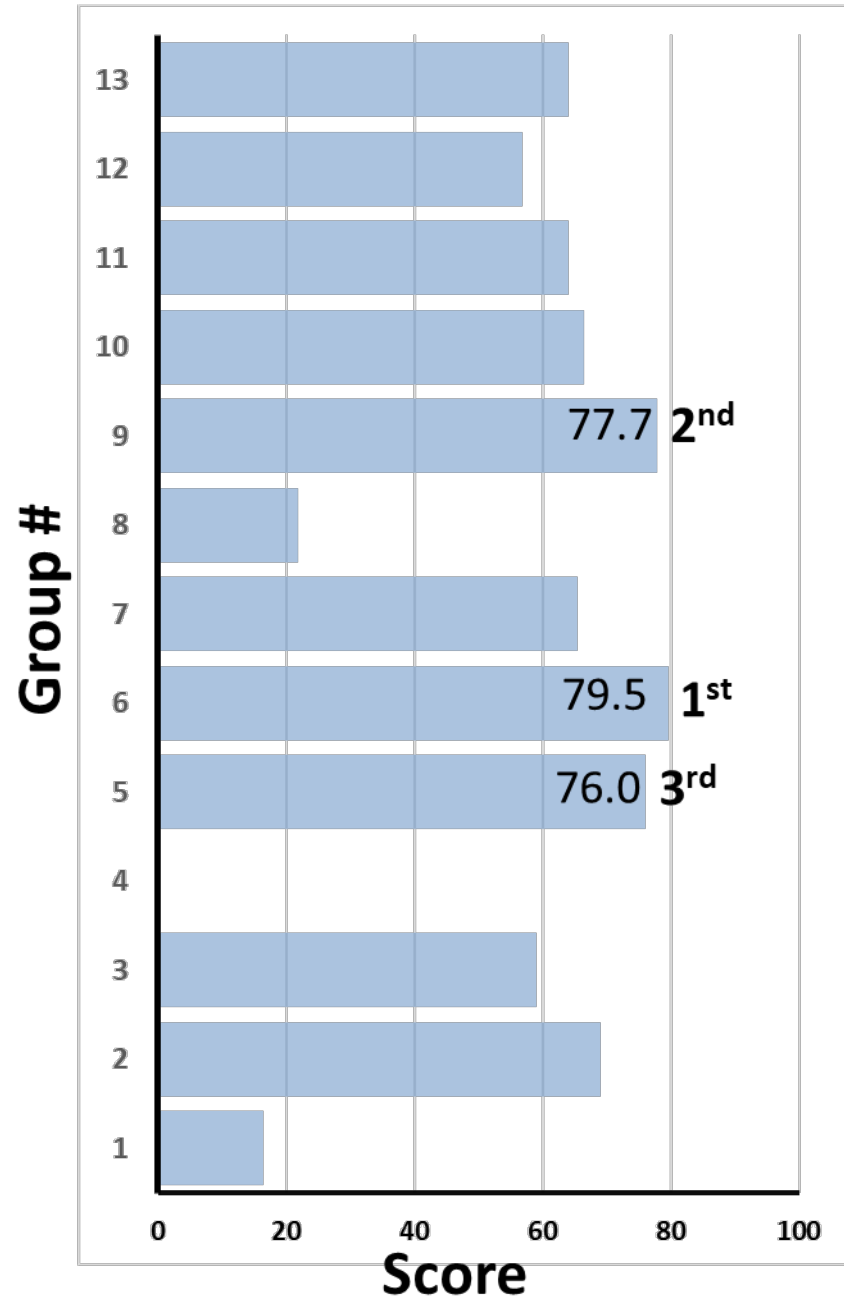

• 1ST PLACE

- David Nevarez-Saenz, Lim Tze Shen (Jason), Manish Mahajan, Pedro Cupertino, Vicknesh Prasad

• 2ND PLACE

- Kale Macormic, Cameron Cropper, Cade Mansfield, Josh McClure, Shanthan Garrepelli

• 3RD PLACE

- Parth Sejpal, Edgar Madrid, Cameron Holston, Nicckhil Murugiyah, Alejandro Fernandez Menendez

Cross-section geometries..

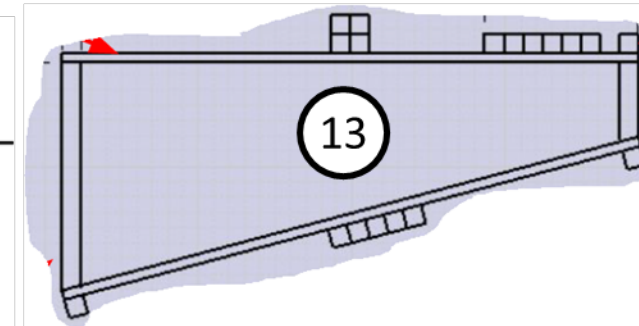
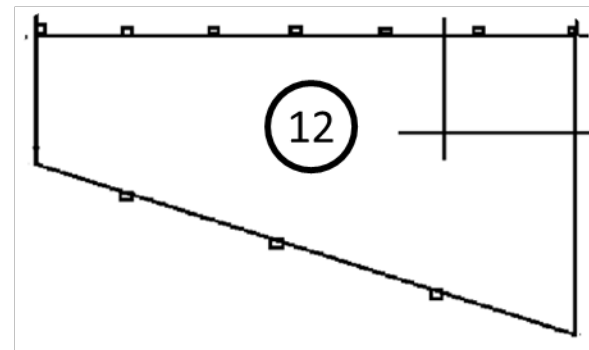
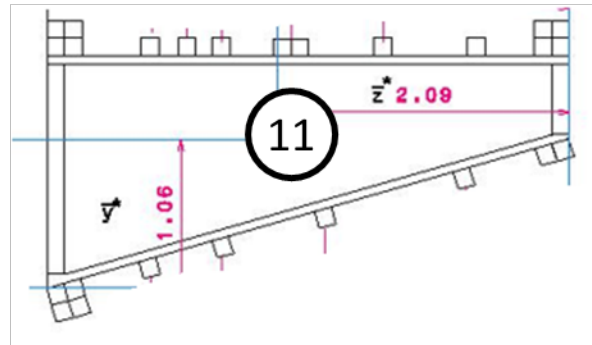
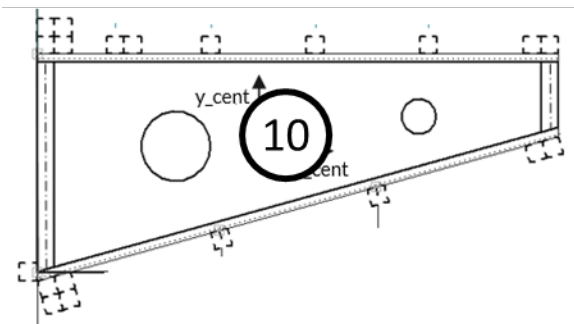
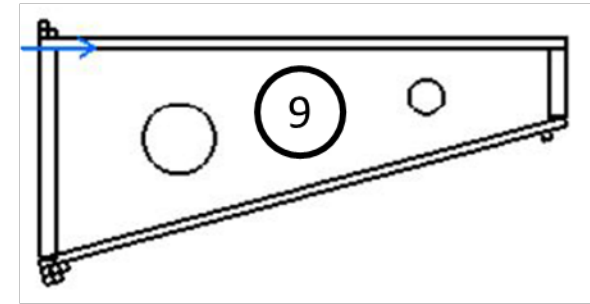
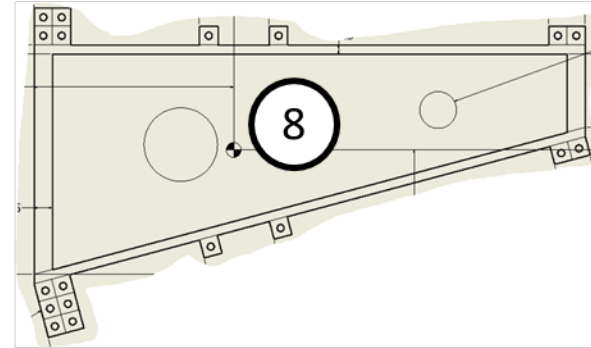
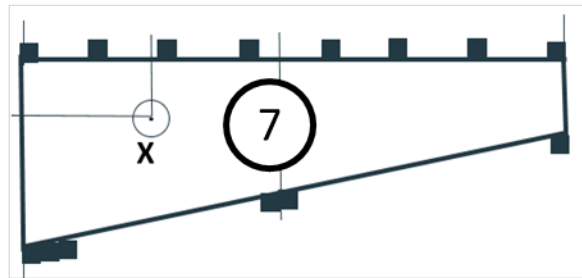
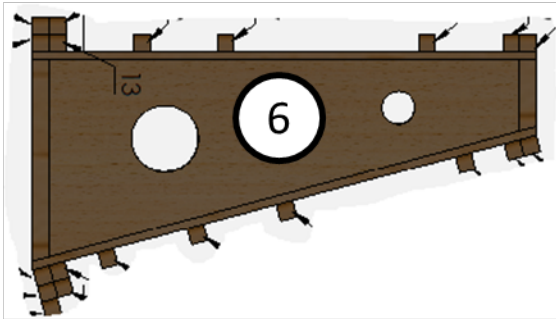
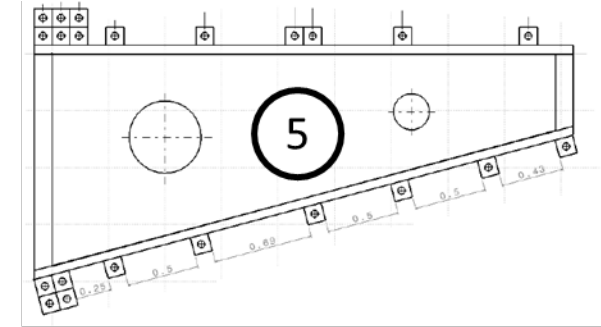
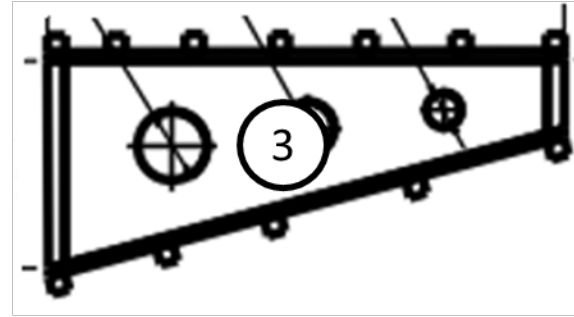
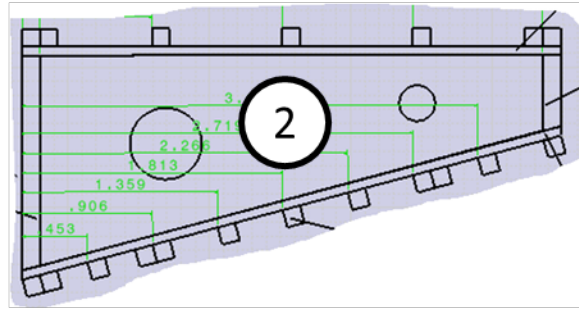
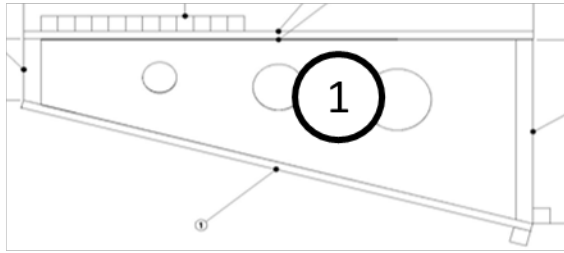

BREAKDOWN OF SCORES

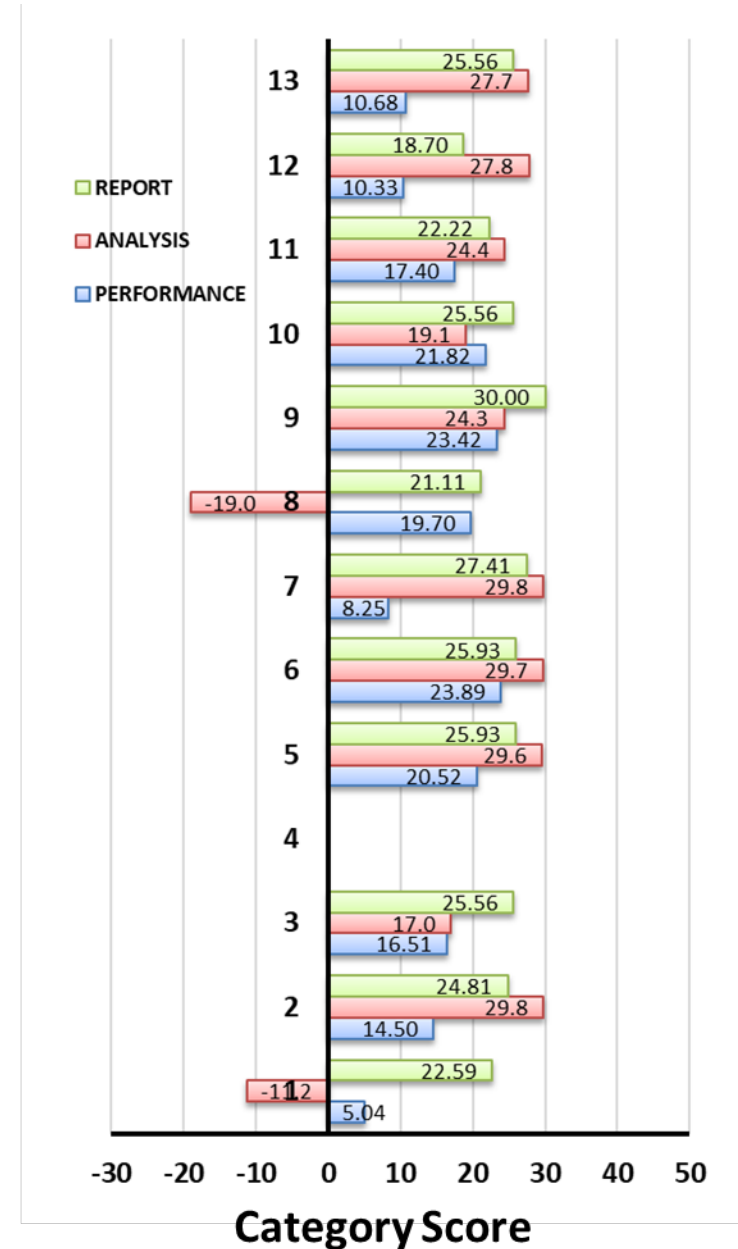
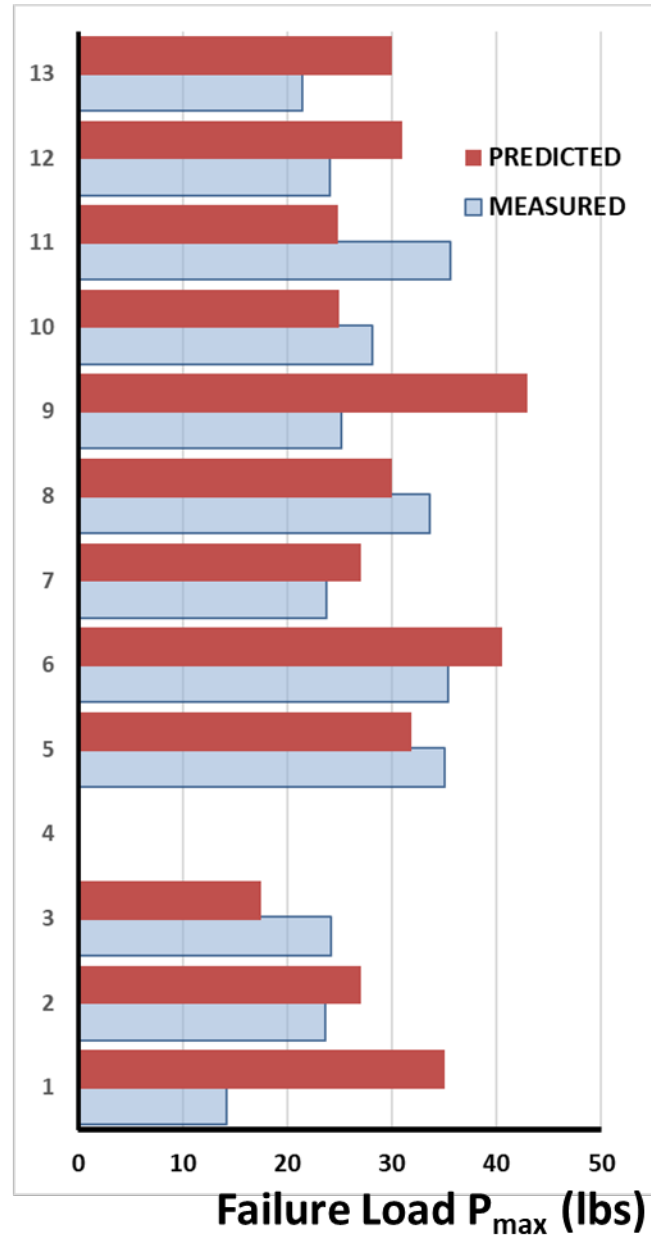
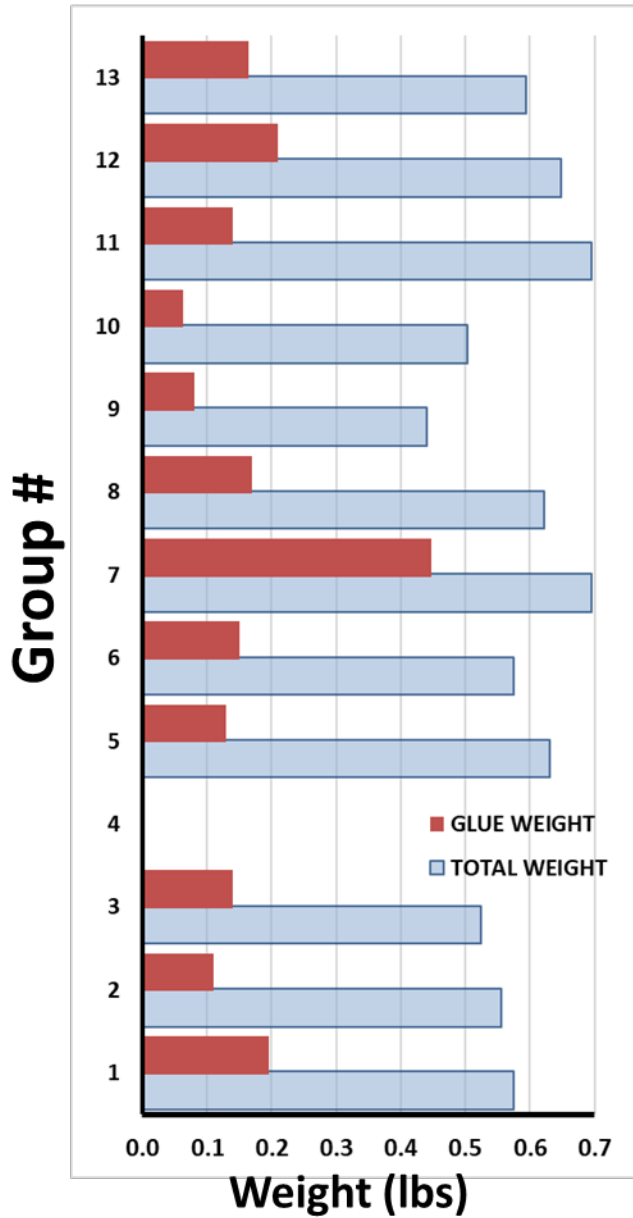

MEASUREMENTS & PREDICTIONS (Q=5 lbs, P=0)

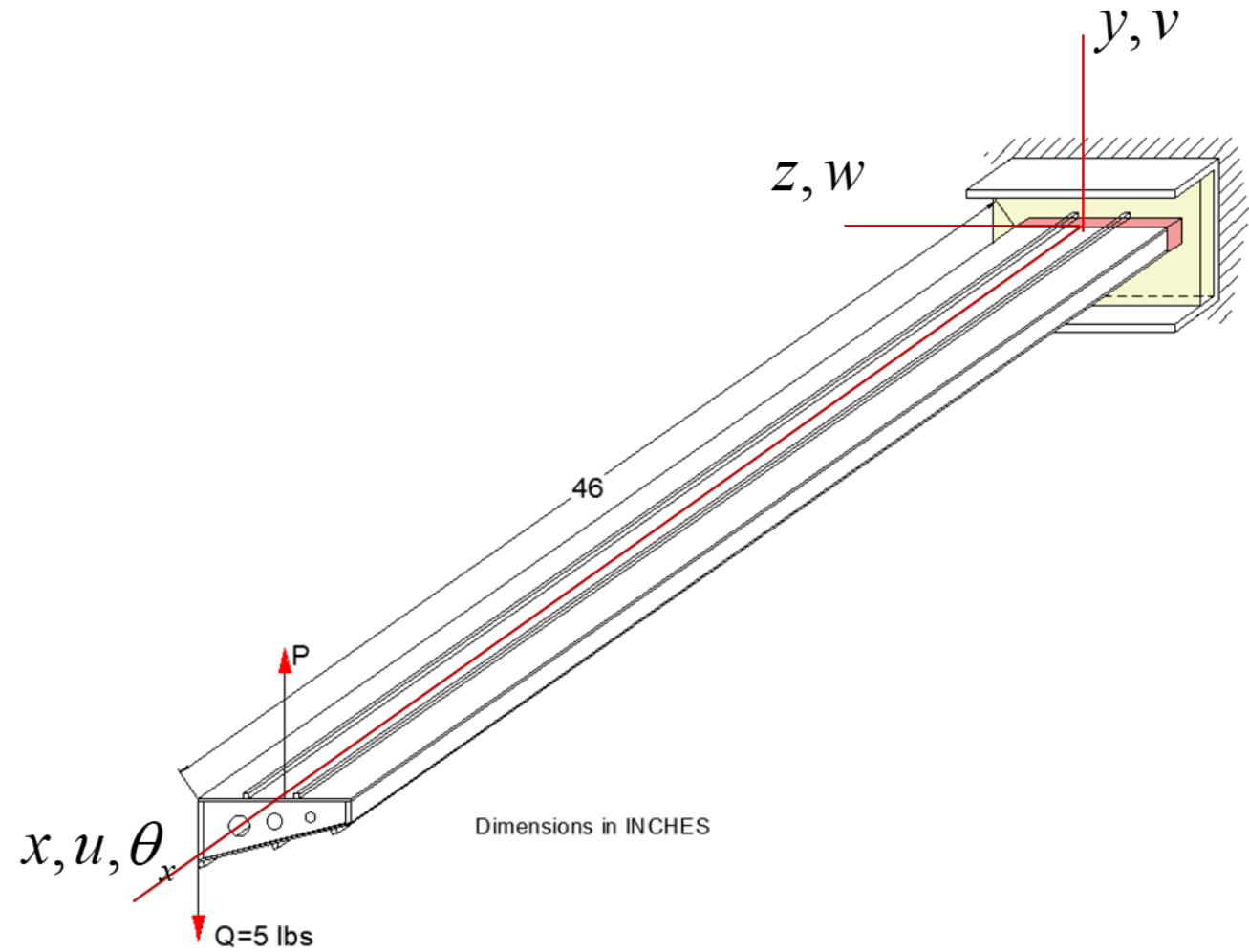
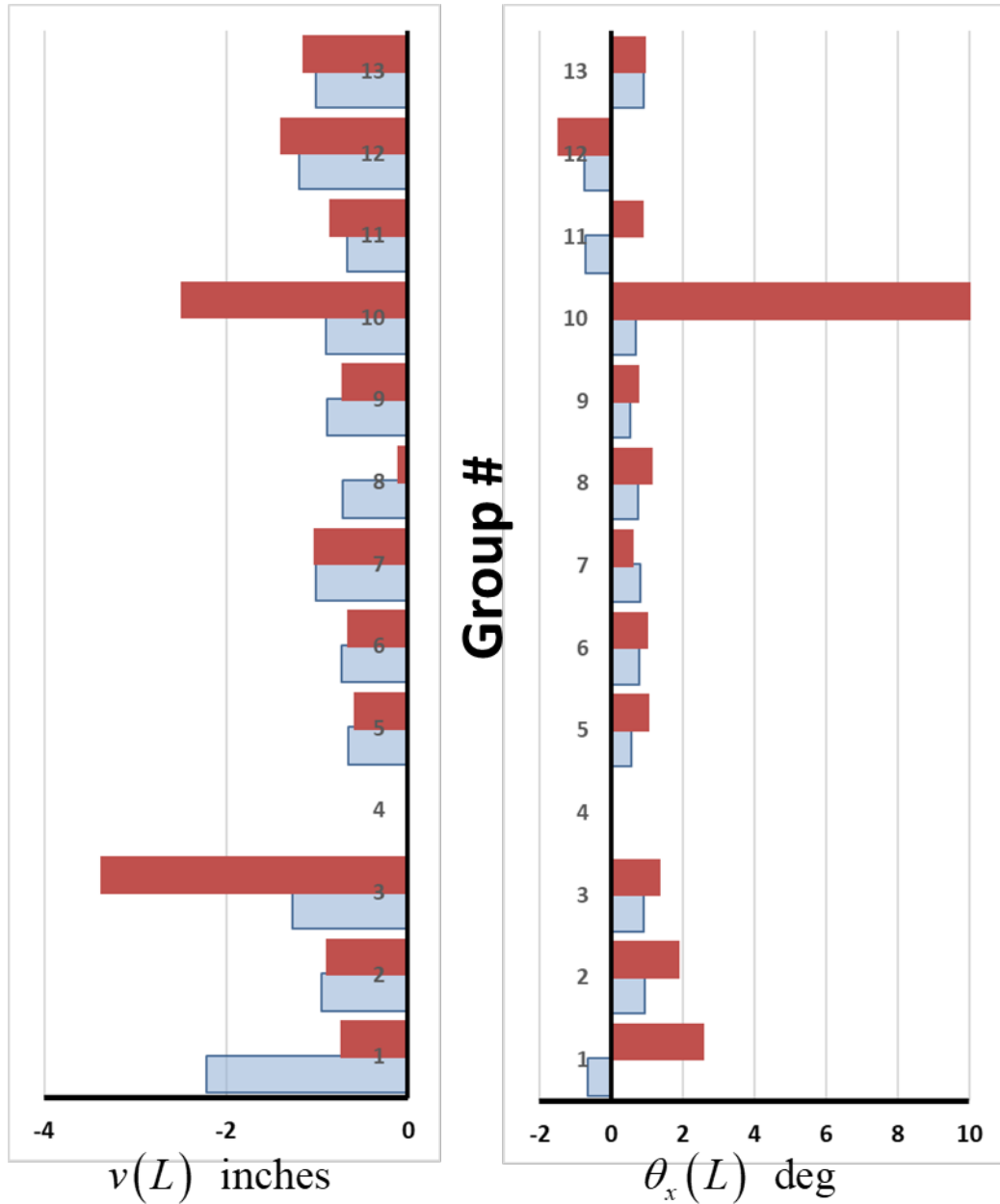

MEASUREMENTS & PREDICTIONS (Q=5 lbs, P=15 lbs)

